



The CYPHER

Newsletter of the Southern Arizona Chapter
American Guild of Organists

Volume 45, Number 7
March 2026

Chapter Website: www.saago.org

2025-26 calendar at a glance

Fauré Requiem, Northminster Sanctuary Choir
Sunday, March 8, 9:45 a.m.
Northminster Presbyterian Church

Young Voices Rejoice! 8th Annual Children's Choir Festival
Saturday, March 7, 10 a.m.
Northminster Presbyterian Church

POSTPONED
SAAGO—Bachathon Members' Recital
Sunday, Mar. 22, 3 p.m.
St. Alban's Episcopal Church

Janet Tolman with Arizona Symphonic Winds
Sunday, April 12, 3 p.m.
Christ Church United Methodist

SAAGO—How the West Was Won, Valerie Harris
Saturday, Apr. 18, 10 a.m.
St. Andrew's Presbyterian Church

Dong-ill Shin, Organ Catalina Organ Festival
Monday, Apr. 27, 7 p.m.

St. Michael's Festival Choir
Saturday, May 2, 3 p.m. & 7 p.m.
St. Michael's and All Angels Episcopal Church

SAAGO—Look, Ma, No Hands!, Using ForScore Valerie Harris
Saturday, May 9, 10 a.m.
Catalina United Methodist Church

March 2026

Please Note: Our March 22nd program—The Bachathon Members' Recital—has regrettably been postponed.

Johann Sebastian Bach (March 31, 1685 - July 28, 1750)



A portion of the Bach window at the *Thomaskirche*

"Bach is a colossus of Rhodes, beneath whom all musicians pass and will continue to pass. Mozart is the most beautiful, Rossini the most brilliant, but Bach is the most comprehensive: he has said all there is to say. If all the music written since Bach's time should be lost, it could be reconstructed on the foundation which Bach laid." — Charles Gounod

"... the most stupendous miracle in all music!" — Richard Wagner

"If Beethoven is a prodigy of man, Bach is a miracle of God." — Gioachino Rossini

"Bach is the beginning and end of all music." — Max Reger

"Now there is music from which a man can learn something." — W. A. Mozart (on hearing Bach motets in Leipzig)

Play Bach on March 22!

Looking ahead to April 18—How the West was Won presented by Valerie Harris, Dean, CAZAGO

**AMERICAN GUILD
OF ORGANISTS**

**SOUTHERN ARIZONA
CHAPTER**

P.O. Box 31315
Tucson, AZ 85751-1315

EXECUTIVE COMMITTEE

DEAN
Raymond Ryder

SUB DEAN/PROGRAM CHAIR
VACANT

SECRETARY & TREASURER
David Horr

ADVERTISING
VACANT

MEMBERSHIP
Lars Andersen

HOSPITALITY
Delores Schultz

EDITOR, *THE CYPHER*
Stardust (Dusty) Johnson

PUBLICITY
Richard Hockett

MEMBER-AT-LARGE
Kathryn Snodgrass

MEMBER-AT-LARGE
Mark Stockwell

LIAISON, UNIVERSITY OF ARIZONA
Pamela Decker

CHAPLAIN
The Rev. Canon David Benedict
Hedges, BSG

*To contact an Executive Committee
member by email or phone, please
use your membership directory.*

Our chapter has a generic email
address:

southernarizonaago@gmail.com.

This email will be checked by an
Executive Committee member at
least twice daily. You may continue
to contact members using their email
and phone numbers printed in the
membership directory, which is not a
public document.



The CYPHER

Stardust (Dusty) Johnson, *Editor* (skj5@cox.net)

**Submission Deadlines for the 2025-2026 season
are the 15th of each month.**

NOTE: Chapter members are invited to submit program information for inclusion in THE CYPHER. We want to include your programs!

Please send program descriptions, along with pertinent information—title, date, location, time, brief description, cost, and photos—to Dusty Johnson, *CYPHER* editor. The information will appear in the print edition as well as in the online edition. Material may be edited as needed.

Please email information to

Dusty Johnson, editor, at skj5@cox.net by the 15th of the month. You may also send it via U.S. mail.

Advertising space available

Full page, \$150
Half page (horizontal), \$100
Quarter page (vertical), \$75
Quarter page (horizontal) \$75
Business card size, \$75
Website, any size, \$50

A *as in an organ from one blast of wind
To many a row of pipes the soundboard breathes.*
Milton—*Paradise Lost*. Bk. I. L. 708.

AGO EXECUTIVE DIRECTOR
James Thomashower
212-870-2311

NATIONAL PRESIDENT
Eileen Hunt
212-870-2310

WEST REGION AMBASSADOR
Nelson H. Dodge
818-468-9870



Message from the dean...

Dear Colleagues,

The past several weeks have been a roller coaster of delights and discouragements. Perhaps you can relate. Recently I had slightly more than 24 hours of rehearsals interspersed with sleep, equipment set-up and tear-down, and a few breaks (such as driving, breakfast and lunch). Rehearsals included the entire program for the spring concerts of Sonoran Bells as well as the 'alumni' piece for this year's Ensemble concert of the Tucson Music Teachers Association.

In stressful periods, such as these past few weeks, I sometimes feel as though I've lost my sense of humor, but a cartoon someone sent me makes me smile. The cartoon pictures a student with books in hand looking at a directory/map. A sign on the wall above the map reads 'Philosophy Department,' and the location on the map is labelled "Why are you here?" It's not a question the creates any sense of a

anxiety for me, but it is a question I sometimes ask myself.

In light of the SAAGO organ crawl to Phoenix and my recent weekend of rehearsals (not to mention the regular, weekly rehearsals and services in which many of us participate), the answer that comes to my mind is: Connections. I draw strength from connections... Connections with our shared musical and cultural heritage, and, just as important, or perhaps even more important, connections with one another.

And so, despite the time and energy involved, I look forward to each subsequent rehearsal. I look forward to renewing my connections with fellow musicians and with the wide and varied world of music. (time to practice...)

Raymond T. Ryder, Dean

Präludium und Fuge Es-dur (per organo pleno)

Johann Sebastian Bach, BWV 552

Präludium
♩ = 50

Manuale

Pedal

Man.

Ped.

Chapter and Member Programs

Requiem, Gabriel Fauré

Northminster Sanctuary Choir
Sunday, March 8, 9:45 a.m.
Northminster Presbyterian Church
2450 E. Fort Lowell
Donation

Under the direction of Dr. John T. Brobeck, the Sanctuary Choir performs the stunningly beautiful Fauré *Requiem* accompanied by Dave Horr, organ, and an instrumental ensemble. In contrast to some other composers' *Requiem*s, the Fauré *Requiem* presents a more serene, consoling view of death and the afterlife.

Steinway Series: Bernadette Harvey, Piano

Saturday, March 21, 4 p.m.
Saint Philip's in the Hills
Free, donations gratefully accepted.

Concert featuring internationally renowned Australian pianist Bernadette Harvey.

Janet Tolman, Organ, with the Arizona Symphonic Winds

Sunday, April 12, 3 p.m.,
Christ Church United Methodist
655 N. Craycroft Rd.
Free

The Arizona Symphonic Winds, under the direction of László Veres, will for the first time in its 40-year history, perform a major work with organ, featuring organist and past chapter dean, Janet Tolman, in Saint-Saens "Finale" from "Symphony No. 3." Comprised of 65 volunteers, Arizona Winds, presents concerts throughout the Tucson area and is well known for its free concerts in the park. The band frequently showcases both professional and amateur soloists as well as talented young performers at its concerts. Both László Veres and Janet Tolman are well known to the Tucson musical community. Be sure to mark your calendar for this unique performance.



SAAGO—How the West Was Won Valerie Harris

Saturday, Apr. 18, 10 a.m.
St. Andrew's Presbyterian Church
7650 N. Paseo Del Norte

Valerie Harris, Dean, CAZAGO, will present a particularly interesting workshop regarding the intermingling of the development of the Arts, specifically music, in the West in conjunction with the arrival of the railroads.

Dean Harris is a concert organist, church musician, presenter and educator, who performs regularly as guest recitalist on the historic Aeolian-Skinner organ at the Tabernacle on Temple Square in Salt Lake City, Utah, and at the Musical Instrument Museum on the 1859 Robjohn organ. She holds a DMA in Organ Performance from Arizona State University, where she studied with Kimberly Marshall. She holds a Master's in Organ Performance and a Graduate Certificate of Church Music from Shenandoah Conservatory and a Bachelor of Music degree from Brigham Young University



Dong-ill Shin, Organ Catalina Organ Festival

Monday, Apr. 27, 7 p.m.
Catalina United Methodist Church
2700 E. Speedway Blvd.
\$\$

Don-ill Shin is a renowned South Korean organist who is also professor at Yonsei University as well as university organist. He is well known for winning major international competitions and for his innovative collaborations with traditional Korean instruments and classical artists like Yo-Yo Ma.



SAAGO—Look, Ma, No Hands, Using ForScore

Valerie Harris
Saturday, May 9, 10 a.m.
Catalina United Methodist Church
2700 E. Speedway Blvd.

Dr. Harris presents a workshop on using ForScore, the sheet music digital app which allows musicians to organize their music libraries digitally and to turn pages via screen taps, custom gestures, or hands-free with a Bluetooth pedal. It also has practice aids which allow the performer to track practice time, set goals, and use features, such as a pitch pipe.



Catalina Organ Festival

2025-2026 Season



Dong-ill Shin

Monday, April 27, 2026 - 7:00 PM

Internationally acclaimed for his exceptional technique and musical insight, Dong-ill Shin has performed at major festivals and concert halls around the world and earned top prizes at leading international competitions. Currently Professor of Organ and University Organist at Yonsei University in Seoul, he brings artistry, depth, and brilliance to every performance.

Catalina United Methodist Church
2700 E Speedway Blvd, Tucson AZ

\$10 Student
\$25 Seniors
\$30 under 60



VISIT WWW.CATALINAMETHODIST.ORG/ORGAN-FESTIVAL/ FOR INFO AND TICKETS!

Bach Memorial at Leipzig

Available Position



PIANIST/ORGANIST

St. Mark's Presbyterian Church
Tucson, Arizona

ABOUT ST. MARK'S

Moved by compassion and rooted in faith, we are a community actively engaged in ministries of peace, justice and reconciliation. Gospel-based hospitality and welcome form the heart of our congregation. We are LGBTQIA+ inclusive, committed to gender and racial equity, and honor the dignity of all persons. We are thoughtful; we are creative; we are joyful; we are persistent! Through worship, prayer, and action, we seek to become the Beloved Community reflecting the love and justice of Jesus Christ. Learn more about us at www.stmarksaz.org

POSITION OVERVIEW

St. Mark's Presbyterian Church is seeking a Pianist/Organist to provide instrumental music for worship services and serve as accompanist for our church choir. This is a part-time, salaried position averaging 10 hours per week annually. The Pianist/Organist reports to the Music Director with accountability to the Lead Pastor/Head of Staff.

Recap—Phoenix Organ Crawl



Richards & Fawkes Organ

L to R: Quinton Hurst, Raymond Ryder, Joan Lusenhop, Dusty Johnson, Doug Leightenheimer, Rhonda Edginton (guest artist), Scott Jones, Delores Schultz, Mark Stockwell, Ilona Kubiaczyk-Adler (host). Missing from the photo: Laura Silva and Stan Kartchner. Pinnacle Presbyterian Church. Photo, Quinton Hurst

Chapter members had a great time visiting two organs in Phoenix, plus hearing a concert and visiting the Music Instrument Museum. The day-long activities culminated with dinner at Organ Stop Pizza where members not only had great pizza, but were treated to fun music performed by Brett Valliant, organist. As they say, everyone had a great time!!



The MIM, photo Dee Schultz



La Casa de Cristo, Berghaus Organ, Photo Dee Schultz



Organ Stop Pizza, Mesa, photo, Dee Schultz



“Young Voices Rejoice!”

Tucson’s 8th annual Children’s Church Choir Festival

Saturday, March 7, 2026, 10:00-3:00pm
Northminster Presbyterian Church
2450 E. Ft. Lowell
Corner of Ft. Lowell and Tucson Blvd

Young Voices Rejoice is a children’s choir festival involving many Tucson children’s choirs. Come and join us for an exciting day as we join together in song. Interested choirs can choose to sing individually and/or in the mass choir. The day will include rehearsals, games/activities, choir chimes, lunch and a performance for family and friends. Children need to wear a red T-shirt or blouse and bring a sack lunch. **Free!!!!**

Interested Children’s Choir directors please contact Gloria Day, Director, Northminster Presbyterian Church Children’s Choirs, gjeanned@aol.com for registration forms. Festival music will be selected based on number and age of participants.



ST MICHAEL'S FESTIVAL CHOIR 2026

- ◆ Motivated and self-driven singers of any age are invited to participate in this community ensemble
- ◆ Singers will receive scores, recordings, and part tracks. The expectation is that they learn the music on their own, then come prepared to two or more of the rehearsals, plus the dress rehearsal (April 29 at 6:30pm).
- ◆ Performances are on May 2, 2026 at 3 p.m. and 7 p.m. at St Michael's Episcopal Church (602 N Wilmot Rd)
- ◆ The Choir will sing four pieces totaling about 25 minutes of music (music does not need to be memorized—maybe except for one piece)
- ◆ There is no fee to participate; however, singers will be asked to offer a donation of \$30, or as much as is feasible for them. Donations cover the costs of music, accompanist, and all the instrumentalists.
- ◆ The first half of the concert will be the Poulenc Organ Concerto (the instrumentalists that we have for this piece (strings and timpani) are who we have for the choral pieces.)
- ◆ More information and an online form to register is here: <https://form.jotform.com/260335609037152>

Dr. Chris Fresolone, Director of Music
520-886-7292
music@stmichael.net

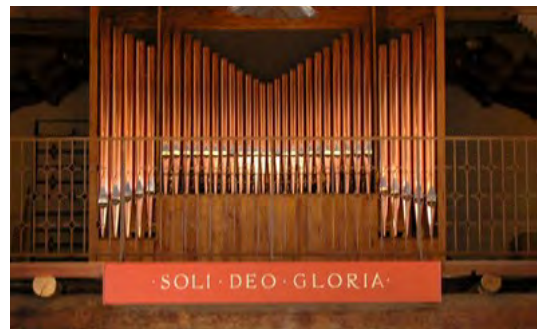

Arizona Symphonic Winds under the direction of László Veres

Chaplain's Reflection



Lent is sometimes called the "springtime of the soul." Here in the northern hemisphere, Lent comes in the springtime of the year as well. This has led to some beautiful theological imagery around the growth of seeds, awaking from winter slumbers, and preparing to bloom. While Easter is a more

obvious time for such imagery, with hymns like "Now the green blade riseth," and "In the bulb there is a flower," Lent has this going on as well. In the Episcopal Hymnal 1982, we find hymn 149, "Eternal Lord of love, behold your Church." There we sing: "If dead in you [Jesus], so in you we arise, you the firstborn of all the faithful dead; and as through stony ground the green shoots break, glorious in springtime dress of leaf and flower, so in the Father's glory shall we wake." Lent is a time for growth in our interior lives - just as seeds are waking, germinating, and stirring under the soul, so the inward turn at Lent, with prayer, fasting, reading of the Word, and almsgiving to those in need are like fertilizers that grow something inside us which is to bloom in God's good time.

Lent is also a very busy season for church musicians as preparations and rehearsals are underway for our Holy Week and Easter services. This will vary according to the tradition of the churches you serve, but it's a busy time for all of us, and I assure you of my prayers for you as you lead God's people in cleansing their hearts in Lent, and giving praise to the Risen Lord at Eastertide.

The Rev. Canon David Benedict Hedges, BSG
Rector, Saint Michael & All Angels Church
(520) 886-7292



Roy Johnson Memorial Scholarship

Students may apply for a scholarship!

Established by the Southern Arizona Chapter of the AGO in memory of Professor Roy Andrew Johnson, the scholarship is available to assist in funding organ study as follows:



- ◆ lessons at any level through collegiate;
- ◆ introductory organ lessons for pianists;
- ◆ Registration fees for an educational event, including a Pipe Organ Encounter (POE);
- ◆ for collegiate level students, registration fees for regional and national conventions of the AGO.
- ◆ for collegiate level students, full membership in the American Guild of Organists, Southern Arizona Chapter.

Scholarship awards for organ study will range from \$350 to \$1500. For educational events, the scholarship will cover the cost of registration. Application forms are online at www.saago.org.

March Composers' Birthdays

Chopin, Vivaldi, Ravel,
C.P.E. Bach, Barber, Wolf,
Rimsky-Korsakov, Mussorgsky,
Telemann,
J.S. Bach,
Haydn

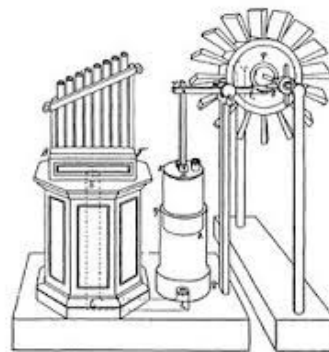

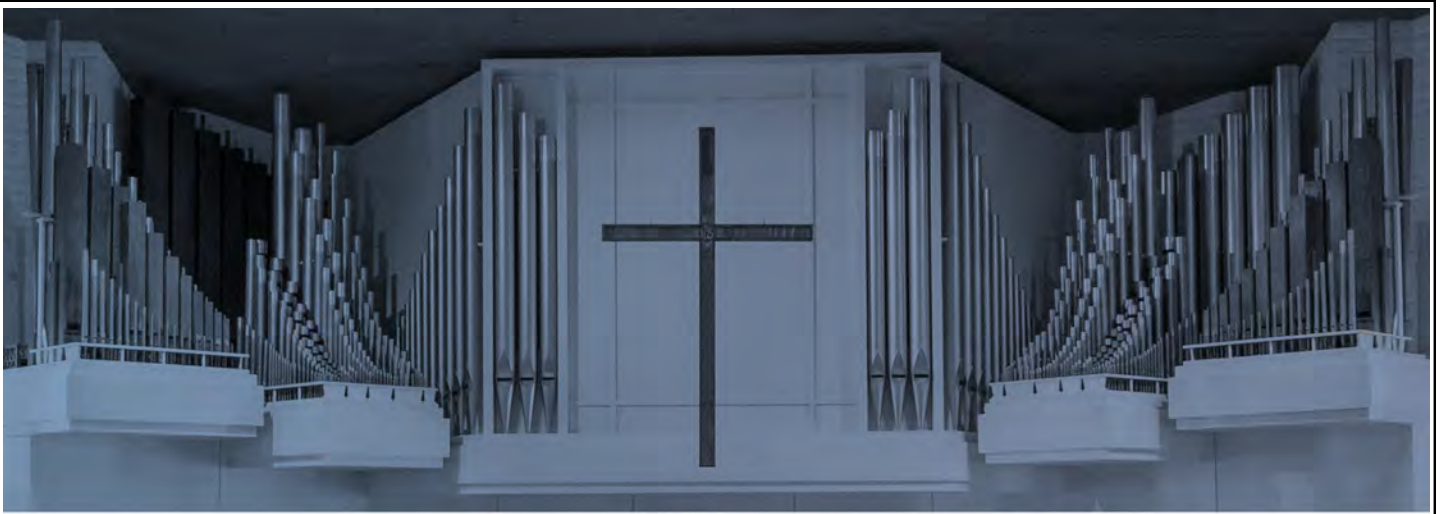

Our pipe organ is *swell*
We're *positive* you'll want to *stop* and enjoy it



At Lutheran Church of the Risen Savior, we:
Love God - Love Neighbors - Share Jesus

Come hear the sounds of the Holtkamp Organ, Opus 2112.

Traditional Worship: Sundays at 9:00AM

Check our website for upcoming concerts:

www.risen-savior.com/concertseries/



555 S. LA CAÑADA DR. GREEN VALLEY, AZ 85614 • (520) 625-2612

Updated SAAGO & Member Programs

Steinway Series: Bernadette Harvey, Piano

Saturday, Mar. 21, 4 p.m.
Saint Philip's in the Hills Episcopal Church

Fauré Requiem, Sanctuary Choir

Sunday, March 8, 9:45 a.m.
Northminster Presbyterian Church

Postponed:

SAAGO—Bachathon SAAGO Members' Recital

Sunday, Mar. 22, 3 p.m.
St. Alban's Episcopal Church

Janet Tolman with Arizona Symphonic Winds

Sunday, April 12, 3 p.m.
Christ Church United Methodist

SAAGO—How the West Was Won, Valerie Harris

Saturday, Apr. 18, 10 a.m.
St. Andrew's Presbyterian Church

Dong-ill Shin, Organ

Catalina Organ Festival

Monday, Apr. 27, 7 p.m.
Catalina United Methodist Church

St. Michael's Festival Choir

Saturday, May 2, 3 p.m. & 7 p.m.
St. Michael's and All Angels Episcopal Church

SAAGO—Look, Ma, No Hands?, Using ForScore Valerie Harris

Saturday, May 9, 10 a.m.
Catalina United Methodist Church

Youth of St. Philip's Fundraising Concert

Saturday, May 9, 7 p.m.
Saint Philip's in the Hills Episcopal Church

All the Bells and Whistles

Sunday, May 17, 3 p.m.
Christ Church United Methodist

SAAGO—Summer Social, Potluck & Business Meeting

Sunday, June 7, 4 p.m.
Colonia Verde Clubhouse

— End of Season —

*"I was obliged to be industrious. Whoever is
equally industrious will succeed equally well."*

—J.S. Bach:

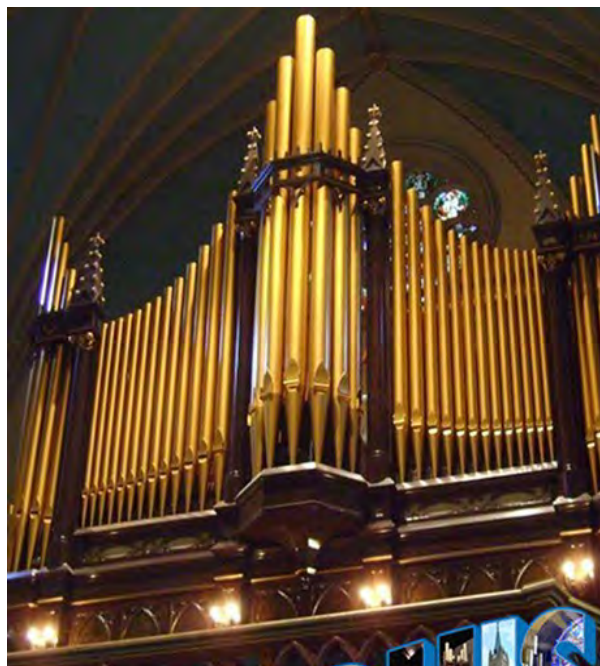

Meet us in
ST. LOUIS
2026 AGO National Convention

Italian Virginal for sale

Zuckerman virginal, built in 1984, in excellent condition, with good, solid soundboard. Inscribed with a quote from Monteverdi's "L'Orfeo," which reads, "I am Music which brings peace to the troubled heart."

Asking price: \$1,900

Contact: Jan Flaaten, 602-670-1594
jflaaten@gmail.com





THE UNIVERSITY OF ARIZONA SCHOOL OF MUSIC ORGAN STUDIO

ISABELLE B. HARRIS ORGAN, HOLSCLAW HALL

Dr. Pamela Decker

Professor of Organ and Harpsichord

pdecker@email.arizona.edu

520-204-5691

For more information please contact Christina

Beasley, Assistant Director, Student Success

Email: cswanson@arizona.edu



music.arizona.edu



THE UNIVERSITY OF ARIZONA
COLLEGE OF FINE ARTS

School of Music



Worship Through *Music!*

In Person or Online

SUNDAYS

9:45AM TRADITIONAL SERVICE

PIPE ORGAN & CHOIR

(CONTEMPORARY 8AM, 11:30AM)

LIVESTREAM

youtube.com/npctucson

*Find the
hope you're
looking for!*



2450 E Fort Lowell Rd · Tucson, AZ · 85719 · (520) 327-7121

PLAN YOUR VISIT
npctucson.org



October 17-19, 2025

Voices of Immigrants

Folk Songs from the Irish, English, Scandinavian, Jewish, Mexican and Cuban traditions



November 21-23, 2025

Give Me Your Tired

SHAW *To the Hands*
LAURIDSEN *Lux Aeterna*
Stephen Paulus Emerging Composers Competition Winner

December 11-14, 2025

Lessons & Carols by Candlelight An American Christmas

December 17, 2025 Holiday Special

January 16 -18, 2026

Music of the Pioneers

COPLAND *Old American Songs*
Stephen Foster songs, hymns, African American Spirituals

February 27-March 1, 2026

I Dream a World

RUNESTAD *Dreams of the Fallen*
BOYER *Dreaming a World*

April 17-19, 2026

West Side Story & The Great American Songbook



THE AMERICAN DREAM

Celebrating America's 250th
Chronicling the American
Journey through Song

"We hold these truths to be self-evident, that all men are created equal..."
—Preamble to the Declaration of Independence



TUCSON'S TWO-TIME GRAMMY-NOMINATED ENSEMBLE

THE 22ND SEASON 2025-2026

CLOSE-UP VOCAL RECITALS

January 20



Will Liverman

March 3



Filigree Ensemble

April 7



Jennifer Johnson Cano

TICKETS & INFORMATION AT
TRUECONCORD.ORG
OR CALL OUR TEAM AT
(520) 401-2651



III/32
Trinity Lutheran Church
MISSION, KANSAS

Quimby Pipe Organs, Inc.
P.O. Box 434 Warrensburg, MO 64093 | 660.747.3066 | info@quimbypipeorgans.com | www.quimbypipeorgans.com



National Convention, July 6–10, 2026
St. Louis, MO
Hosted by the St. Louis Chapter
AGOSTL2026@agostlouis.org
Burnell L. Hackman, Coordinator



Johann Sebastian Bach's manuscript of the first sheet of his Fantasia and Fugue for keyboard in C minor. Facsimile of the original, published in 1885.

SOUTH MOUNTAIN

MARK MACKEBEN
Owner & Lead Technician
602-334-4303

Phoenix, AZ
southmountainorgan.com
mark@southmountainorgan.com

**JOHANNUS
RODGERS**

ANDERSON
organ works

Full Service for Pipe
& Electronic Organs

"Your concerts are always an amazing experience!"

*Arizona
Repertory
Singers*
Since 1984

Why do we sing?
Because we can't
imagine *not* singing!

Tickets to ARS December and April
concerts available online and at the door.

www.arsingers.org
520.792.8141

Ryan Phillips, M.M., Music Director

facebook.com/arsingers twitter.com/azrepingers

ARTS
COUNCIL
of
ARIZONA



THE PLACE TO BE, ARTISTS TO SEE!
FOXTUCSON.COM



Danú
Mar 13

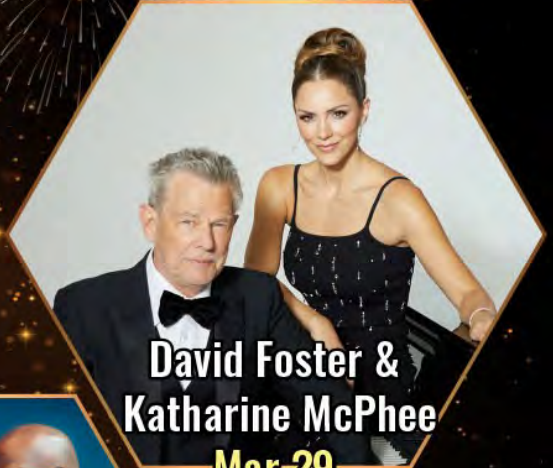

David Foster & Katharine McPhee
Mar 29



SESAME STREET
Live!
Elmo's Got THE MOVES

Apr 15



Christian McBride & Edgar Meyer
Apr 8

Thank you to our season sponsor:
Bert W. Martin Foundation

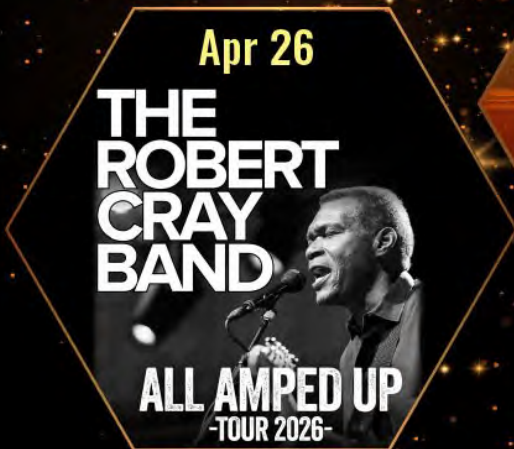

Apr 26
THE ROBERT CRAY BAND

ALL AMPED UP
-TOUR 2026-



The Hot Sardines
Mar 24



Patronize our advertisers



PimaCommunityCollege

www.pima.edu

Dr. Raymond T. Ryder

Music Faculty

West Campus
2202 West Anklam Road
Tucson, AZ 85709-0170

ryder@pima.edu

Tel: 520.206.6862
Fax: 520.206.6020



Church Keyboard

Nelson Dodge
President

nelson@churchkeyboard.com
818-468-9870 mobile
909-599-7899 office | service
www.ChurchKeyboard.com

Consider underwriting a chapter program. Contact Dave Horr, treasurer, for information and possibilities...

DAVID A. HERR

Southern AZ Chapter, American Guild of Organists
Available to Substitute

P.O. Box 31511, Tucson AZ, 85751
(520) 822-7808
dahorr@comcast.net

Support our chapter with a financial gift.

Consider underwriting a concert, making a contribution to the general fund or to the Johnson Scholarship Fund.

DONOR LEVELS

\$500+	Tuba Mirabilis
\$250-\$499	Trompette
\$100-\$249	Diapason
\$50-99	Flute Harmonique
\$1-\$49	Voix Humaine

Please make your check payable to So. AZ AGO
Mail it to

David Horr, Treasurer
P.O. Box 31511
Tucson, AZ 85751

Thank you!
Your gifts make a difference.



**CHRIST CHURCH UNITED
METHODIST**

655 N. Craycroft Rd.
Tucson, AZ 85711

520-327-1116
office@ccumtucson.org
www.ccumtucson.org

Organ Pipes: each pipe, whether metal or wood, is made by hand.



Publication Information: *The Cypher* is a monthly newsletter published by the Southern Arizona Chapter of the American Guild of Organists. It is distributed to chapter members, organists of Tucson churches and surrounding communities, and deans of all chapters in the West Region (Arizona, California, Hawaii, Nevada, Utah, Idaho, Montana, Wyoming, Alaska, and Oregon, as well as Singapore, Taiwan, Hong Kong, and Sydney, Australia.)

Southern Arizona Chapter members who do not request a printed version will receive *The Cypher* via email. Send information for publication to Stardust (Dusty) Johnson at email skj5@cox.net. Please type "Cypher" in the subject line. Views expressed in any of the pieces herein are those of the writers and not necessarily those of the Southern Arizona Chapter of the AGO, its officers or members.